

PART #	VERTICAL CABLE PANEL HEIGHT	RACK UNITS
PCM-119	1.72"	1U
PCM-319	3.47"	2U
PCM-519	5.22"	3U

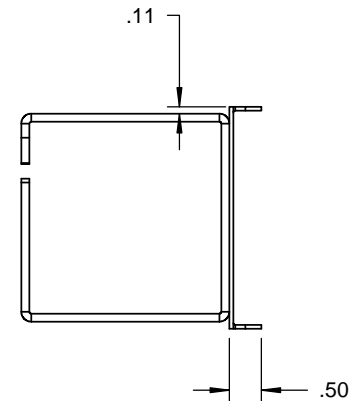
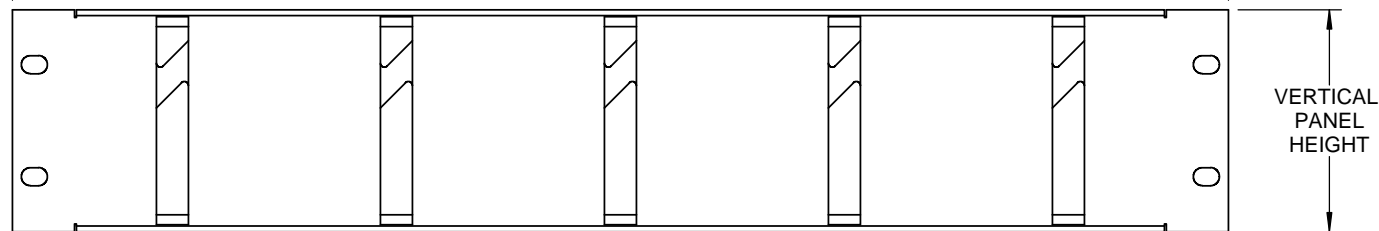
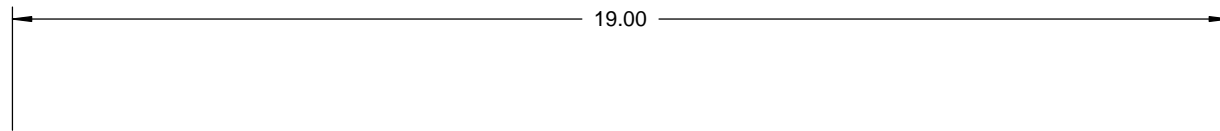
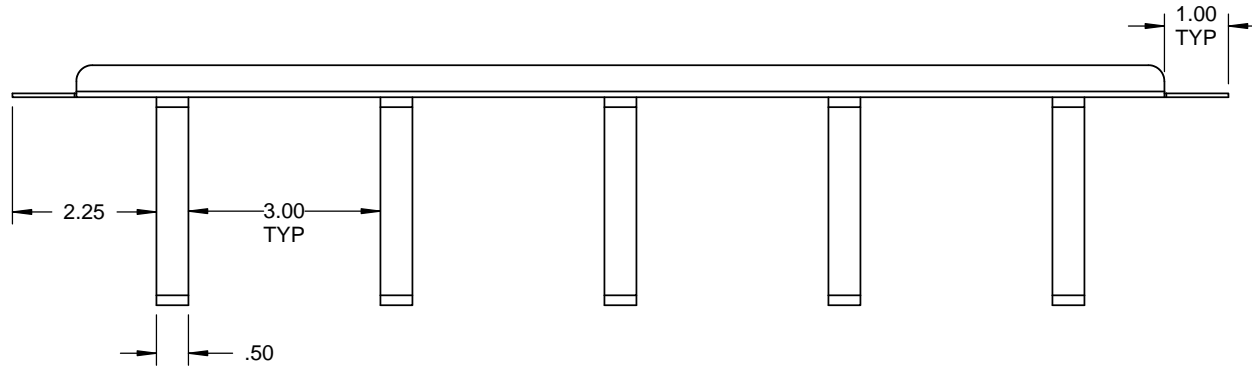
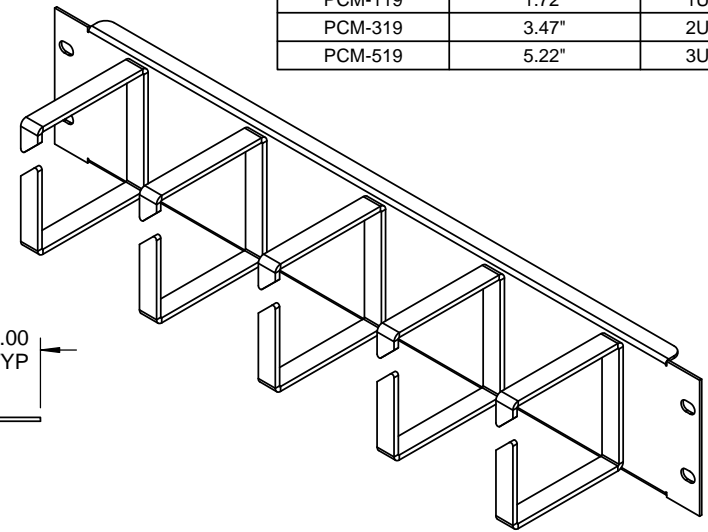

PROPRIETARY AND CONFIDENTIAL
 THIS DRAWING EMBODIES A CONFIDENTIAL PROPRIETARY DESIGN OWNED BY
 PREMIER ENCLOSURE SYSTEMS AND ALL DESIGN, MANUFACTURING, REPRODUCTION,
 USE AND SALES RIGHTS REGARDING THIS DRAWING ARE RESERVED TO PREMIER
 ENCLOSURE SYSTEMS. THE RECIPIENT OF THIS DRAWING ASSUMES CUSTODY
 THEREOF AND AGREES THAT THE INFORMATION CONTAINED HEREIN SHALL NOT BE
 USED, DUPLICATED OR DISCLOSED TO REPRODUCE ARTICLES OR SUBJECT MATTER
 THEREIN WITHOUT WRITTEN PERMISSION OF PREMIER ENCLOSURE SYSTEMS.

DRAWING NO
PCM-XX19
 TITLE
CABLE MANAGEMENT - 19" LONG

FINISH
POWDER COAT
 MATERIAL
16 GA STEEL

REV DATE
10/11/13
SHEET 1 OF 1